

## Data Sheet

# Packet-Master USB12 Bus Analyser

The **Packet-Master USB12** is a Hardware USB Bus Analyser, intended for development of Low and Full Speed USB devices and hubs etc. It comes complete with our Windows application **Graphic USB** for capturing and displaying every detail of the data interactions on a USB link.

---



**Packet-Master USB12**

## Take Control of your USB Development

Chapter 9 of the USB Specification details some seventeen Standard Device Requests which must be correctly implemented in any USB device, in order for the device to be successfully enumerated by the host controller.

When developing a USB-based device it is a major undertaking to implement the basic Chapter 9 Framework correctly as enumeration will simply fail for any number of reasons involving incorrect responses to the requests.

There is no substitute for a USB bus-analyser for revealing the smallest details of the packet transfers which takes place on the bus. Software based analysers can only ever give you a partial picture of what is going on, usually not reporting at all the packets with the errors.

The Packet-Master USB12 connects passively between a host computer and the USB device, and captures all USB activity without influencing the link.



## Benefits of Packet-Master USB12

### ***Save Development Time***

The Packet-Master USB12 will provide you with exact information showing you at which point a device under development is failing. It will save you weeks of wasted development time. In many cases you will find that the error you are looking for is highlighted on the Graphic USB display in a distinctive colour.

### ***Simple Connection***

The USB12 connects passively between a host computer and the USB device, and captures all USB activity without influencing the link. So you can be sure that you are seeing exactly what really happens. All the important timings are displayed.

### ***Understand USB***

When it comes to the USB protocol, a picture is worth a thousand words. The graphical display of Graphic USB immediately provides deeper understanding of the data transfers and their related timings. By examining a working device, you will learn more in a few minutes than from hours of reading the specifications. (Specifications are essential too, but easier to understand when you have a picture in your mind.)

### ***Understand Host Command Sequences***

There is no specification as to the sequence of commands which a device may expect from a host. Some command sequences can be very surprising to the starting-out developer. The Packet-Master USB12 will allow you to examine the sequences for any Operating System /Host Controller combination

of your choice. This will allow you to reveal any false assumptions you may be making that a particular enumeration sequence is standardised.

(As a device developer, just remember that the device should make no assumptions about enumeration sequences, but simply respond correctly to any request it receives.)

### ***Examine Working Devices***

A great benefit available from the Packet-Master USB12 is that it allows you to examine exactly what transactions occur in a working device, perhaps manufactured by a third party. This may reveal your own bad assumptions about how a protocol works, or may show you how many devices on the market do not obey the rules.

Some operating systems have work-arounds for certain common protocol errors, and you may discover some of these first-hand.

Specifications often contain ambiguities. For example, without seeing it for yourself, you might not have realised that there have been two different ways of encoding the version number (bcdUSB) for USB 1.1. Operating systems appear to take the pragmatic approach of accepting either.

### ***Fine-tune Performance***

Much of the effort in developing a new device will go into achieving the throughput required. There is no substitute for seeing the transactions attempted by the host, together with the device's response to them. Armed with this valuable information you will be in the best position to be able to fine-tune your device's performance.

## Hardware Features



**USB12 Front View**

- Power Indicator
- Activity indicator shows presence of data exchanges
- Integral Capture Start and Stop buttons and Capture Indicator
- USB through-connectors for device under test
- Analyses Low Speed (1.5 Mbit/s), Full Speed (12 Mbit/s) or a mixture of both
- Automatically detects speed of link under test
- Economically priced
- Fully Lead Free and RoHS compliant

- USB Bus Powered for convenience of use
- Optional external power input supply (not required, but useful if host won't configure a high-power device)
- High Speed USB (480 Mbit/s) connection to host PC
- Feature connector provides signals for oscilloscope or logic analyser



**USB12 Rear View**

## Software Overview

The Packet-Master USB12 owes a large part of its functionality to the GraphicUSB application, which is supplied with the unit. A simple, yet information-rich display allows you to view every detail of a capture.

This shows the organisation of the screen after a typical capture:

The event pane reveals every detail of data and timing which occurs on the bus. You see exactly what happened in graphic detail.

Any selected event is thoroughly analysed in the details pane. Highlighting an item locates its data in the data pane below.

These toolbar buttons allow less significant events to be filtered out from the display.

Precise timing is shown for every event.

Careful use of colour draws instant attention to protocol anomalies

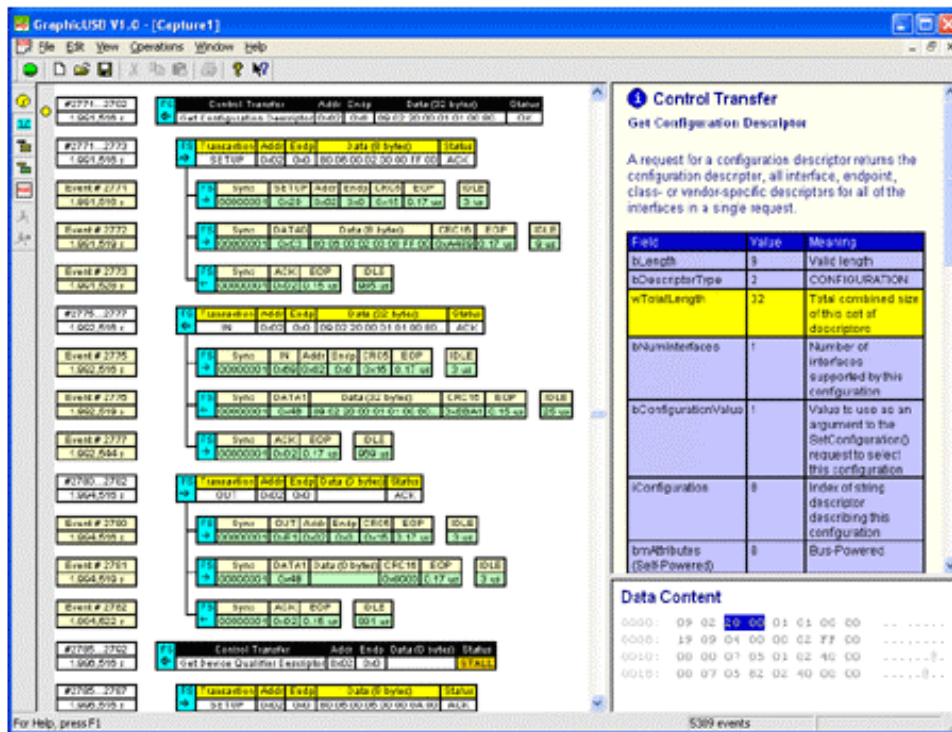

The data pane shows every data byte contained in the selected event.

## Software Features

- Capture controlled from Packet-Master USB12 unit or from Graphic USB screen.
- Captured document shows every detail of data transactions graphically for a fuller understanding of the USB protocol. This includes a detailed visual analysis of each packet.
- Transactions are grouped and summarised with a header row in the event pane. Transfers are summarised with a special header row.
- Filters allow less significant information to be removed from the display to allow you to concentrate on the critical data.
- Each event is analysed in detail, with any significant features explained, and possible errors or warnings highlighted.
- Data pane shows the data content of any packet.
- Comprehensive search functions.
- Events display, detail analysis or data can be printed.
- Standard software up-grades are free of charge from our web site.
- Software can be freely used as a viewer in the absence of the Analyser Hardware.
- A multi-document interface allows comparison between captures.
- Capture size only limited by RAM size.
- Export any range of events to text file, with a chosen level of filtering.
- Export all or chosen descriptors as annotated source code.
- Export data from a selected event, or a range of events.
- Optional Class Analysis modules.

## Mixed Speed On Single Link

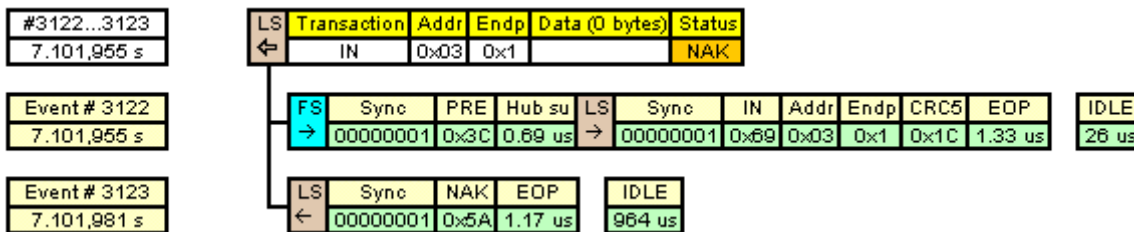

This view of part of a screen-shot from Graphic USB shows a representation of data being transferred at two different speeds on the same link. Each packet is preceded by a coloured marker indicating Full Speed or Low Speed. This makes the function of the PREAMBLE packet very clear. Each Event has a precise timestamp (left). Notice also the detailed timing information for Hub Setup time, End Of Packet duration, and IDLE state time.

## View By Control Transfers

(less significant events filtered)

#70...81 5.064,825 s	FS ←	Control Transfer	Addr	Endp	Data (8 bytes)	Status
		Get Device Descriptor	0x00	0x0	12 01 01 01 09 00 00 08	OK
Event # 83 5.069,084 s		Start of RESET	Duration	End of RESET	IDLE	
		OK	25,996 us	FULL SPEED LINK	744 us	
#116...122 5.126,829 s	FS →	Control Transfer	Addr	Endp	Data (0 bytes)	Status
		Set Address (0x01)	0x00	0x0		OK
#185...203 5.189,833 s	FS ←	Control Transfer	Addr	Endp	Data (18 bytes)	Status
		Get Device Descriptor	0x01	0x0	12 01 01 01 09 00 00 08...	OK
#206...220 5.195,833 s	FS ←	Control Transfer	Addr	Endp	Data (9 bytes)	Status
		Get Configuration Descriptor	0x01	0x0	09 02 19 00 01 01 00 E0...	OK
#223...246 5.200,833 s	FS ←	Control Transfer	Addr	Endp	Data (25 bytes)	Status
		Get Configuration Descriptor	0x01	0x0	09 02 19 00 01 01 00 E0...	OK

By clicking on the filter buttons for less significant events, the sequence of top-level control transfer header rows may be viewed in isolation. This ability to view information at an appropriate level of complexity makes Graphic USB an invaluable tool for getting straight to the heart of the subject.

## Full Analysis and Data Panes

By clicking on an event row in the event pane, a complete analysis of the event is displayed in the analysis pane, and the data content is shown in its entirety in the data pane. Where relevant, any information selected in the analysis pane is highlighted in the data pane for easy identification. All standard requests and descriptors are analysed in detail. Discrepancies are described.

**i Control Transfer**  
**Get String Descriptor 1**

String descriptors use UNICODE encodings.

Field	Value	Meaning
bLength	16	Valid Length
bDescriptorType	3	String Descriptor
bString	"USB Hub"	

### Data Content

```
0000: 10 03 55 00 53 00 ..U.S.
0006: 42 00 20 00 48 00 B. .H.
000C: 75 00 62 00 u.b.
```

## Optional Class Analysis Modules

A number of Class Analysis Options are available. These include

- Human Interface Devices (HID) Class
- Hub Class
- CDC and Comms Class
- Mass Storage Class
- Audio Class
- Image Class
- Printer Class
- Smart Card Class
- Video Class
- Test and Measurement Class
- Wireless Controller Class
- Vendor Class

Each option is available individually. Registering an option allows Graphic USB to display a full analysis of the specific Class transfer.

The screen shot to the right shows the analysis of a HID Report Descriptor.

**i Control Transfer**  
**Get HID Report Descriptor**

Meaning	Value
Usage Page (Generic Desktop Controls)	05 01
Usage (Mouse)	09 02
Collection (Application)	A1 01
Usage (Pointer)	09 01
Collection (Physical)	A1 00
Usage Page (Button)	05 09
Usage Minimum (1)	19 01
Usage Maximum (5)	29 05
Logical Minimum (0)	15 00
Logical Maximum (1)	25 01
Report Count (5)	95 05
Report Size (1)	75 01
Input (Data, Variable, Absolute, Bit Field)	81 02
Report Count (1)	95 01
Report Size (3)	75 03
Input (Constant, Array, Absolute, Bit Field)	81 01
Usage Page (Generic Desktop Controls)	05 01
Usage (X)	09 30
Usage (Y)	09 31
Usage (Wheel)	09 38
Logical Minimum (-127)	15 81
Logical Maximum (127)	25 7F
Report Size (8)	75 08
Report Count (3)	95 03
Input (Data, Variable, Relative, Bit Field)	81 06
End Collection	C0
End Collection	C0

**Input Report**

Usage	Bits
Button 1	1 Bit
Button 2	1 Bit
Button 3	1 Bit
Button 4	1 Bit
Button 5	1 Bit
Not Used	3 Bits
X	8 Bits
Y	8 Bits
Wheel	8 Bits

The shot to the left shows the results of the built-in 'HID Report Descriptor' parser. Each report defined by the Report Descriptor is identified and displayed.

With the HID Class Analysis enabled, each HID report is identified, and the contents analysed.

Examining the analysis of existing devices is an excellent way to learn how a class works, and it has never been easier to reveal the building blocks, than with Graphic USB.

**i Interrupt Transfer**

**Device To Host**

This is a HID IN report. An analysis of the report contents appears below.

**In Report**

Usage	Value
Button 1	0
Button 2	0
Button 3	0
Button 4	0
Button 5	0
X	-5
Y	-1
Wheel	0

**Data Content**

0000: 00 FB FF 00 . . . .

## Test Set-up Connections

To achieve a good capture rate it is important to provide a suitable test environment. The Packet-Master USB12 should preferably be hosted by a good performance PC with a high speed USB connection. This USB host controller should not be shared by any other USB device while doing the testing.

The Packet-Master USB12 will function correctly when connected to a Full Speed link but the capacity will be severely reduced and only low rates of USB traffic may be captured from the device under test.

In a similar fashion it is theoretically possible to use the same host computer for the Packet-Master USB12 and for the Host Under Test. We do not recommend this, but if it is absolutely unavoidable, then you must at least use a separate USB host controller for the device under test. If your computer does not have two host controllers then you will need to buy a plug-in USB host controller card.

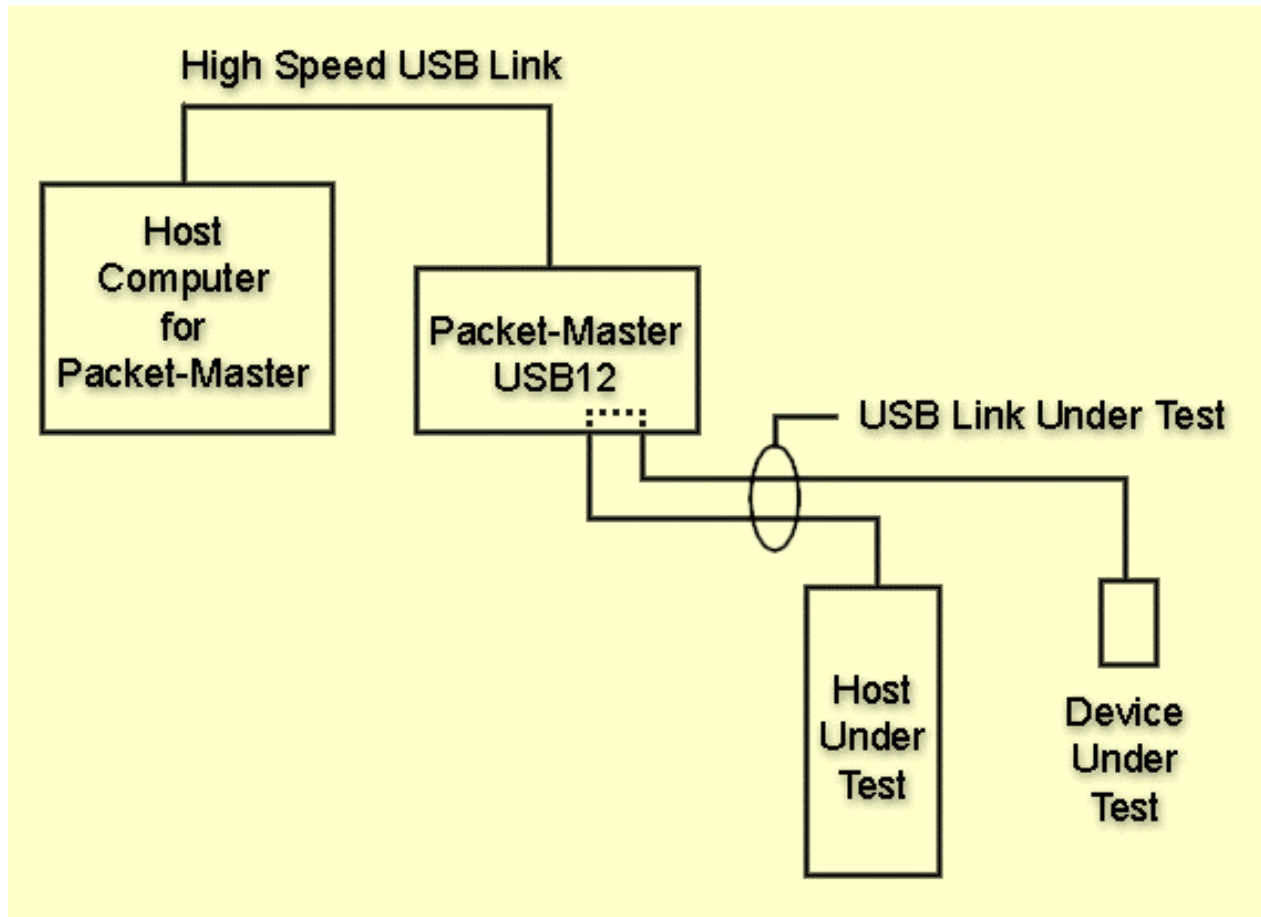

## Cables

As this test equipment, by its very nature, has to connect to a junction of two USB cables in order to probe the data on the link, it is important to keep the cables between the 'device under test' and the 'host under test' as short as possible (for example 1m), and to use good quality cables.

## Specifications

### **System Requirements (for Packet-Master USB12 Host)**

- Pentium 3 - 600MHz
- PC with High Speed USB port should be dedicated to the capturing. (Actual target device should be connected to a different Host Computer to ensure reliable capture bandwidth)
- Windows XP (Service Pack 1 or better) preferred. Also Windows 2000 / ME / 98SE.
- CD ROM / DVD Drive
- 128MB RAM
- 100MB space on Hard Disk

Note: A good performance machine is recommended for good capture rate.

### **Physical Specifications**

Weight:	155 g
Dimensions:	129 x 100 x 31 mm
Temperature:	0°C - 40°C
Humidity:	20% - 80% non condensing

### **Electrical Requirements**

The Packet-Master USB12 normally derives its power from the Host computer's USB connection.

Power:	150mA from USB host
	Optionally zero mA from USB if powered externally

### **Safety etc.**

CE compliant.

### **Signals Available on Feature Connector**

- D+
- D-
- Decoded Data
- Decoded Clock
- Packet Sync Detected

### **Standard Accessories**

Packet-Master USB12 comes complete with the following:

- Graphic USB control software on CD
- USB 2.0 cable x 2
- Manual on CD

### **Optional Accessories**

- Feature Connector Terminating Board
- External Power Supply

### **Software Options**

- HID class analysis
- Hub class analysis
- Communications class analysis
- Printer class analysis
- Mass Storage class analysis
- Audio class analysis
- Vendor class analysis
- Other options in preparation



*For further information contact:*

MQP Electronics,  
Park Road Centre,  
Malmesbury,  
Wilts, SN16 0BX, UK

Tel: **+44 (0) 1666 825 666**

Fax: **+44 (0) 1666 825 141**

email: **sales@mqp.com**

web site: **http://www.mqp.com**